

Reciprocating Compressors EUROCOMP Series

Air delivery from 112 to 1050 l/min – Pressure 10 and 15bar



What do you expect from your workshop compressor?

Quality results can be achieved only by using quality tools and equipment. A dependable source of compressed air delivered by a high performance compressor is therefore essential for many applications. KAESER's Eurocomp series of stationary reciprocating compressors have successfully served trade and industry for years. The choice of horizontal, vertical or free-standing air receiver allows these highly versatile compressors to be installed in any location.

Advantages of KAESER Eurocomp compressors include:

- **Made in Germany:** Quality KAESER compressor blocks manufactured from premium grade materials ensure maximum performance and outstanding service life.
- **Cool compressed air** thanks to an efficient aluminium after-cooler that also serves as a fan guard.
- **Maintenance-free** power transmission via direct coupling of the drive motor to the compressor block.
- **Dual anti-vibration mounts**, fitted as standard, keep sound levels to a minimum and prevent vibration transfer to the floor.
- **Choice of sound enclosures** to reduce sound levels by up to 10dB(A), supplied fitted or as retrofit kits.

Providing exceptional performance and reliability, KAESER Eurocomp compressors ensure a quality compressed air supply that you can count on.

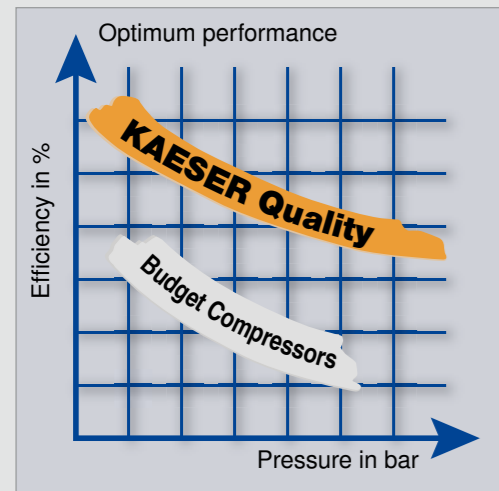

EUROCOMP – Quality and Performance



Quality compressor block from KAESER – Made in Germany

Made from premium grade materials and subjected to rigorous inspection, each Eurocomp compressor block component is meticulously machined and expertly assembled. Transmission losses are virtually eliminated, as the durable electric motor and compressor block are directly coupled to one another.



Corrosion-resistant valves

The valves in Eurocomp compressors feature stainless steel valve reeds and lift limiters which prevent carbon build up, improve discharge valve closure and extend operational life.



Highly effective cooling

Oil and compressed air temperatures are kept to a minimum by means of a large fan and cooling fins. This highly efficient cooling system significantly extends the life of the compressor and pneumatic tools.

Quality: Made in Germany

All KAESER Eurocomp compressor components, such as the compressor block and the electric motor, are made to the very highest standards of German design and engineering. As a result, Eurocomp compressor users benefit from greater system performance and considerably extended compressor service life. KAESER Eurocomp compressors are designed to provide many years of reliable service and to ensure a dependable supply of quality compressed air.



Quality Compressed Air for Trade and Industry

- Compact: Direct coupling of the drive motor to the compressor block
- Quality you can count on: Compressor block Made in Germany
- Versatile: The right compressor for every application

- Space saving design with vertical air receiver
- Low speed operation reduces sound levels and increases service life
- Sound enclosures available ready fitted or as retrofit kits



EUROCOMP – Horizontal air receiver version without sound enclosure	Single stage, 10 bar								Two stage, 15 bar					
	EPC 340-100 ¹⁾	EPC 440-100 ¹⁾	EPC 630-100 ¹⁾	EPC 630-250	EPC 840-100 ¹⁾	EPC 840-250	EPC 1100- 500	EPC 1500- 500	EPC 150-2- 100-F ⁴⁾	EPC 230-2- 100	EPC 420-2- 250	EPC 550-2- 250	EPC 750-2- 500	EPC 1000-2- 500
Displacement	340	440	660	840	1100	1500	150	230	420	550	750	1000		
Effective air delivery ¹⁾ at 6 bar l/min	230	300	440	590	770	1050	–	–	–	–	–	–	–	–
Effective air delivery ¹⁾ at 8 bar l/min	215	280	410	544	715	975	116	192	344	460	620	836		
Effective air delivery ¹⁾ at 12 bar l/min	–	–	–	–	–	–	112	118	336	450	610	820		
Receiver volume	90	90	250	90	250	500	90	250	500					
Motor power ²⁾ 400 V kW	1.7	2.4	3	4	5.5	7.5	1.1	1.7	3	4	5.5	7.5		
Motor power ²⁾ 230 V kW	–	–	–	–	–	–	1.25	–	–	–	–	–		
Number of cylinders	1	2	2	2	2	2	2	2	2	2	2	2		
Sound pressure level ³⁾ dB(A)	64	64	76	78	80	80	69	69	76	78	80	80		
Length mm	1120	1150	1540	1150	1590	2050	1200	1140	1540	1590	2040			
Width mm	350	500	570	590	600	690	800	460	440	570	600	680	720	
Height mm	910	870	950	1130	960	1140	1300	1330	870	1190	1220	1330	1340	
Weight kg	73	89	95	166	100	165	235	245	80	90	175	180	280	285
EUROCOMP – Horizontal air receiver version with sound enclosure														
Sound pressure level ³⁾ dB(A)	56	56	67	68	70	72	–	61	67	68	70	72		
Length mm	1150	1150	1540	1150	1590	2050	–	1170	1630	1710	2050			
Width mm	470	610	610	730	–	470	610	730						
Height mm	1000	1010	1080	1250	1080	1250	1410	1400	–	1000	1240	1260	1410	
Weight kg	123	125	155	230	160	230	345	352	–	130	245	247	444	447

EUROCOMP – Vertical air receiver version without sound enclosure	Single stage, 10 bar					Two stage, 15 bar				
	EPC 440-250	EPC 630-250	EPC 840-250	EPC 230-2-250	EPC 420-2-250	EPC 550-2-250	EPC 550-2-350	EPC 750-2-500	EPC 1000-2-500	
Displacement	440	660	840	230	420	550	750	1000		
Effective air delivery ¹⁾ at 6 bar l/min	300	440	590	–	–	–	–	–		
Effective air delivery ¹⁾ at 8 bar l/min	280	410	544	192	344	460	620	836		
Effective air delivery ¹⁾ at 12 bar l/min	–	–	–	188	336	450	610	820		
Receiver volume	250	250	250	250	350	500				
Motor power ²⁾ 400 V kW	2.4	3	4	1.7	3	4	5.5	7.5		
Number of cylinders	2	2	2	2	2	2				
Sound pressure level ³⁾ dB(A)	64	76	78	76	78	80	80			
Length mm	730	710	730	710	710	740	940			
Width mm	640	640	640	640	670	730	910			
Height mm	1720	1810	1820	1720	1890	1920	2060	2080		
Weight kg	125	150	156	150	175	177	190	325		
EUROCOMP – Vertical air receiver version with sound enclosure										
Sound pressure level ³⁾ dB(A)	56	67	68	66	67	68	68	70	72	
Length mm	810	920	810	920	920	1090				
Width mm	470	640	640	640	730	920				
Height mm	1900	1970	1900	1970	2040	2140				
Weight kg	160	230	235	200	250	258	313	395	400	

¹⁾ Effective delivery measured as per VDMA norm 4362 – ²⁾ Electrical connection: 400 V, 3 Ph, 50 Hz; 230 V, 1 Ph, 50 Hz –
³⁾ Sound pressure level as per ISO 2151 and basic standard ISO 9614-2, tolerance: ± 3 dB(A) – ⁴⁾ Mobile unit
⁵⁾ With applicable type approval

¹⁾ Effective delivery measured as per VDMA norm 4362 – ²⁾ Electrical connection: 400 V, 3 Ph, 50 Hz
³⁾ Sound pressure level as per ISO 2151 and basic standard ISO 9614-2, tolerance: ± 3 dB(A)

Base-mounted compressors for detached installation

- The compressor unit and the compressor can also be installed separately
- Optionally ready fitted with sound enclosure (also available as retrofit kit)
- Available single or two stage compression to meet all compressed air needs



With sound enclosure
Also available for retrofit

Single stage, 10 bar

Two stage, 15 bar

EUROCOMP – Base-mounted compressors without sound enclosure	Single stage, 10 bar						Two stage, 15 bar					
	EPC 340-G	EPC 440-G	EPC 630-G	EPC 840-G	EPC 1100-G	EPC 1500-G	EPC 150-2-G	EPC 230-2-G	EPC 420-2-G	EPC 550-2-G	EPC 750-2-G	EPC 1000-2-G
Displacement	350	440	660	840	1100	1500	150	230	420	550	750	1000
Effective air delivery ¹⁾ at 6 bar l/min	230	300	440	590	770	1050	—	—	—	—	—	—
Effective air delivery ¹⁾ at 8 bar l/min	215	280	410	544	715	975	116	192	344	460	620	836
Effective air delivery ¹⁾ at 12 bar l/min	—	—	—	—	—	—	112	188	336	450	610	820
Motor power ²⁾ 400 V kW	1.7	2.4	3	4	5.5	7.5	1.1	1.7	3	4	5.5	7.5
Number of cylinders	1	2	2	4	2	2	2	2	2	4	2	2
Sound pressure level ³⁾ dB(A)	64	64	75	78	79	80	69	69	75	77	79	80
Length mm	520		640		800	810	510	520	640		800	800
Width mm	330	500	570	590	690	800	430	440	570	600	670	720
Height mm	510	440	540	550	610	650	440		580	610	630	650
Weight kg	40	50	70		100	130	40	45	70	95	125	130
Control and connecting components incl. hose	•	•	•	•	•	•	•	•	•	•	•	•

EUROCOMP – Base-mounted compressors with sound enclosure												
Sound pressure level ³⁾ dB(A)	54	54	67	72	70	74	59	59	67	68	70	72
Length mm	810		920		1090		810		920		1090	
Width mm	470		610		730		470		610		730	
Height mm	640		730		800		640		730		800	
Weight kg	95	100	130		240	260	95	100	160	170	265	270

¹⁾ Effective delivery measured as per VDMA norm 4362 – ²⁾ Electrical connection: 400 V, 3 Ph, 50 Hz

³⁾ Sound pressure level as per ISO 2151 and basic standard ISO 9614-2, tolerance: ± 3 dB(A)

Suited to a wide variety of applications, Eurocomp compressors provide the user with a highly versatile and reliable source of quality compressed air.

Standard Equipment

Compressor

- Air cooled compressor block with oil ring lubrication (splash oil lubrication up to 2.4 kW)
- Air inlet filter with silencer
- Aluminium cylinder heads and additional cooling pipes ensure excellent heat dissipation
- Multi-chamber, aluminium ring cooler; also serves as a fan guard (3 kW model upwards)
- Low noise, lightweight reed valves
- Oil filler, oil vent, oil drain plug and oil level sight glass
- Motor directly coupled to the compressor block
- Compressor, motor and air receiver fitted with anti-vibration mounts, flexible hose connection between compressor and air receiver
- Anti-vibration mounts between air receiver and floor

Motor

- Four-pole, 1500 rpm, three-phase 400 V/50 Hz
- IP 54 enclosure protection, B 15 construction
- Integrated axial fan for compressor and motor cooling

Optional extras (additional cost)

- Sound enclosure
- Operating hours counter
- Alarm contact
- Electronic condensate drain installed on the air receiver
- Screw adjustable machine feet, or guide rollers
- Foodstuff compliant, synthetic or silicon-free oil
- Power cable with / without plug
- Oil level monitor with automatic shutdown if oil level is too low

Accessories



Star-delta "Start Control"

Control cabinet with automatic star-delta protection combination. Dust and water resistant as per IP 54. With operating hours counter and KAESER CONTROL monitoring module (necessary for motor powers from 5.5 kW).



Electronic condensate drain for retrofit installation

Level-sensing controlled ECO DRAIN condensate drain. Complete set for installation on air receiver. Including all assembly components and fittings.



Compressed air hose

Flexible hose for connection of the air receiver to the compressed air distribution network (hose length 1 m).



Compressed air storage and drying

Galvanised air receiver as per EC-regulation 87/404. Standard fittings comprise: Check valve, type-approved pressure relief valve, pressure gauge, test flange, ball valve. Energy-saving refrigeration dryer for dry compressed air.

Choose the required grade of treatment according to your field of application:

Air treatment using a refrigeration dryer (pressure dew point +3 °C)

Examples: Selection of treatment classes to ISO 8573-1

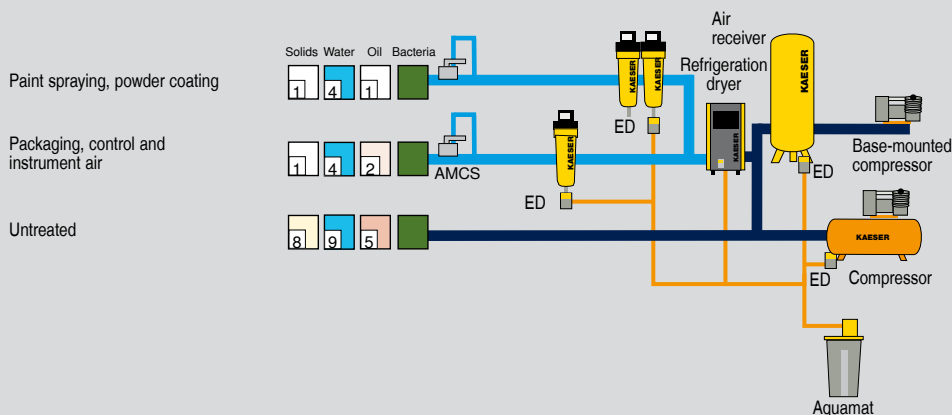

Explanation	
ED	ECO DRAIN
FE	Microfilter
RD	Refrigeration dryer
Aquamats	Aquamats
AMCS	Air-main charging system

Compressed air quality classes to ISO 8573-1(2010):

Solid particles / dust

Class	Max. particle count per m ³ of a particle size with d [µm]*		
	0.1 ≤ d ≤ 0.5	0.5 ≤ d ≤ 1.0	1.0 ≤ d ≤ 5.0
0	e.g. Consult KAESER regarding pure air and cleanroom technology		
1	≤ 20,000	≤ 400	≤ 10
2	≤ 400,000	≤ 6,000	≤ 100
3	not defined	≤ 90,000	≤ 1,000
4	not defined	not defined	≤ 10,000
5	not defined	not defined	≤ 100,000
Class	Particle concentration C _p [mg/m ³]*		
6	0 < C _p ≤ 5		
7	5 < C _p ≤ 10		
X	C _p > 10		

Water

Class	Pressure dew point [°C]
0	e.g. Consult KAESER regarding pure air and cleanroom technology
1	≤ -70 °C
2	≤ -40 °C
3	≤ -20 °C
4	≤ +3 °C
5	≤ +7 °C
6	≤ +10 °C
Class	Concentration of liquid water C _w [g/m ³]*
7	C _w ≤ 0.5
8	0.5 < C _w ≤ 5
9	5 < C _w ≤ 10
X	C _w ≤ 10

Oil

Class	Total oil concentration (fluid, aerosol + gaseous) [mg/m ³]*
0	e.g. Consult KAESER regarding pure air and cleanroom technology
1	≤ 0.01
2	≤ 0.1
3	≤ 1.0
4	≤ 5.0
X	> 5.0

*) At reference conditions 20°C, 1 bar(a), 0% humidity