

SECOTEC® Refrigeration Dryers

Air flow rate 0.6 to 25 m³/min



Why is it necessary to dry compressed air?

The atmospheric air drawn into a compressor is a mixture of gases that always contains water vapour.

However, the amount of water vapour that air can carry varies and is mostly dependent on temperature. As air temperature rises – which occurs during compression – the air’s capability to hold moisture increases also.

When the air is cooled its capacity to hold moisture reduces, which causes the water vapour to condense. This condensate is then removed in the centrifugal separator, or in the air receiver, downstream from the compressor. Even then, the air can still be completely saturated with water vapour.

This is why, as the air cools further, significant amounts of condensate can accumulate in the air distribution piping and at take-off points.

System failure, production downtime and costly service and repair work are therefore unavoidable without additional air drying.

Refrigeration dryers usually offer the most efficient solution for the majority of compressed air applications. Compressed air drying is now made even more cost-effective with KAESER’s advanced SECOTEC® systems.

Function diagram

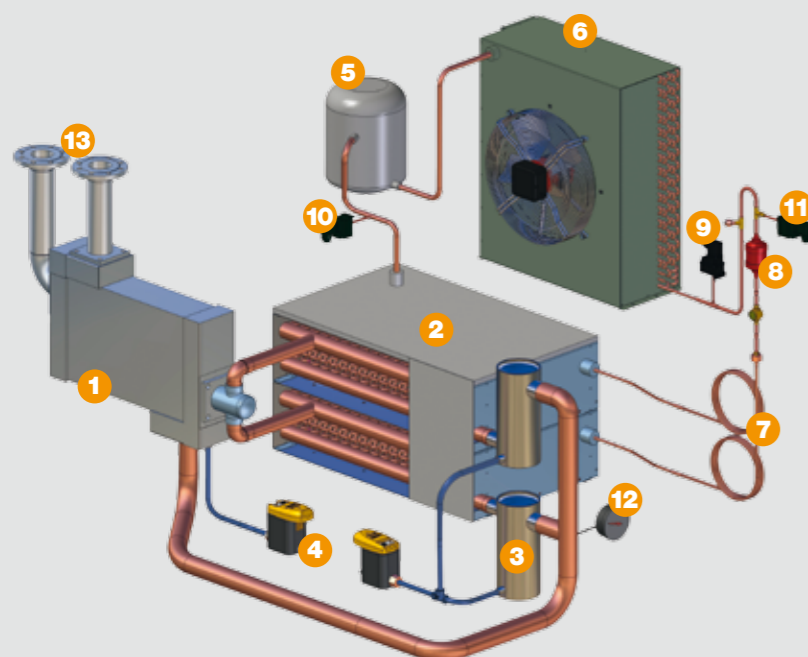

**SECOTEC®
Enhanced energy savings**

The SECOTEC® System

In developing the SECOTEC dryer range, KAESER’s goal was to produce a system that consumed minimal energy and which would provide optimal reliability and user-friendliness.

The resulting SECOTEC system from KAESER KOMPRESSOREN fulfils all of these requirements and, in contrast to most refrigeration drying systems, uses a highly efficient cycling system: SECOTEC Control. Therefore, the dryer’s refrigeration circuit consumes power only when necessary.



- 1 Air / air heat exchanger
- 2 Air / refrigerant heat exchanger with thermal mass
- 3 Condensate separator
- 4 Condensate drain (ECO DRAIN)
- 5 Refrigerant compressor
- 6 Condenser
- 7 Capillary tubes
- 8 Filter dryer
- 9 High pressure switch
- 10 Low pressure switch
- 11 Fan pressure switch
- 12 PDP indicator
- 13 Compressed air inlet/outlet



Designed and built by KAESER

As one of the world’s foremost compressed air system providers and manufacturers, KAESER ensures that every SECOTEC dryer provides exceptional performance. Each unit is built in accordance with the very highest quality standards at the KAESER Gera plant and undergoes

stringent quality inspection as per KAESER’s Quality Management System.

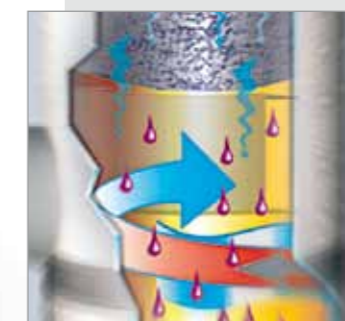

Condensate separator

As with all KAESER products, SECOTEC dryers are designed for maximum reliability. They are equipped with a specially designed condensate separator made from corrosion-resistant stainless steel*) that reliably removes condensate from the air even under fluctuating airflow conditions.

*) TA 5 model uses a zinc die-cast condensate separator



Minimal pressure drop

SECOTEC dryers use flow-optimised piping and usually do not require the use of a pre-filter. Pressure losses are therefore kept to a minimum, which means that maximum system pressure can be significantly reduced. This leads to considerable savings, as each 1 bar reduction represents a 6 % decrease in power consumption and also means less air is lost through leakage.

Air consumption over a 24-hour period

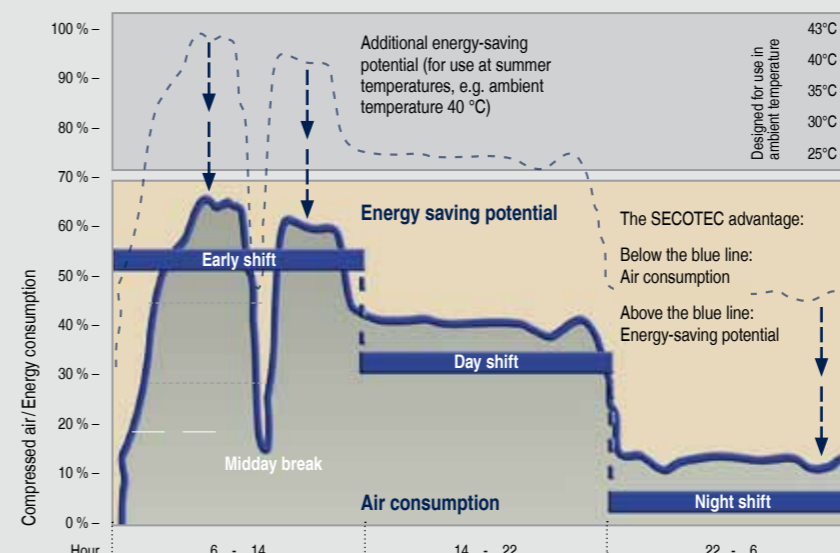

The cost saving effect of the SECOTEC® system

The TB 19 dryer saves a total of approximately € 600 per year compared with dryers which use hot gas by pass control. This cost saving is calculated as follows:

$$(8760 \text{ h} - 1000 \text{ h}) \times 0.43 \text{ kW} \times 0.20 \text{ €/kWh} = \text{€ 667}$$

The graph (left) shows a typical compressed air consumption profile. SECOTEC dryers save energy because the refrigerant system is shut down during breaks, periods of low demand and downtime – the control system operates without preset run-on periods. The integrated thermal mass ensures that the system is ready for operation at all times.

SECOTEC® – Energy savings all day, every day

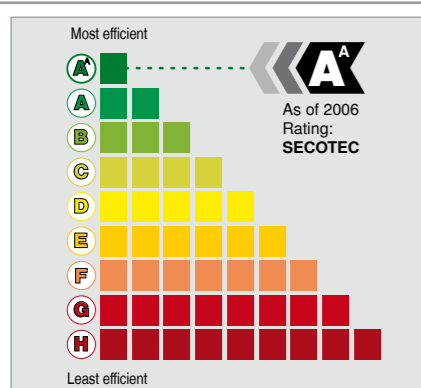

Energy savings all day, every day, with SECOTEC® Control

The high capacity thermal mass is cooled down to cut-out temperature by the refrigeration circuit and extracts the heat from the compressed air that flows through the heat exchanger. As soon as the temperature of the thermal mass rises to the cut-in temperature the refrigerant compressor starts and cools it down again. This feature considerably enhances efficiency compared with non-cycling controllers.

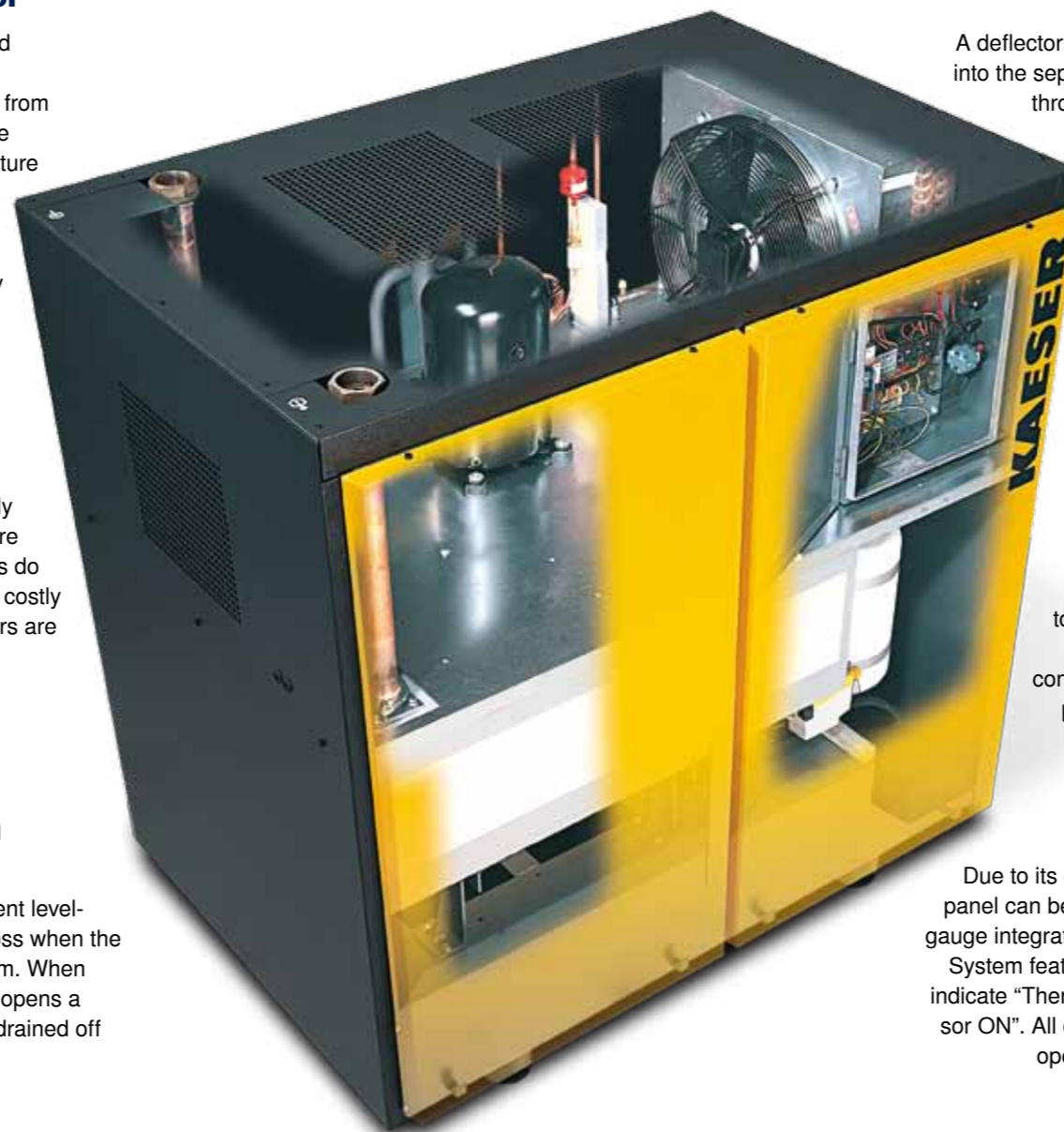

Minimal pressure drop for greater energy savings

The air/air and refrigerant/air heat exchangers are equipped with generously sized smooth-flow copper piping to ensure minimal pressure drop. SECOTEC dryers do not require a pre-filter, which means that costly pressure drops caused by additional filters are avoided.



Dependable, energy saving condensate drainage

The ECO-DRAIN is fitted with an intelligent level-sensing control that prevents pressure loss when the condensate is drained from the air system. When the collector tank is full, the level sensor opens a diaphragm valve and the condensate is drained off without pressure loss.



Simple, cost-effective servicing

All components in SECOTEC dryers are easily accessible when the unit's panels are removed. Service valves are also provided to make inspection of the refrigerant circuit as simple as possible. Furthermore, the condenser is located at the front of the dryer, which allows possible dirt accumulation to be quickly spotted and rectified. Logical component layout and the tower design not only enable maintenance work to be carried out easily, but also significantly reduce servicing requirement and therefore costs.



Efficient stainless steel condensate separator

A deflector plate forces the compressed air that streams into the separator into circular motion. The air then flows through a stainless steel wire mesh that ensures 99.9 % water separation from the air. This allows the required pressure dew point of +3 °C to be reliably maintained. The stainless steel separator tank*) is completely corrosion resistant.



Industrial quality control cabinet for increased safety

Every SECOTEC dryer is EN 60204-1 compliant and is tested for electromagnetic compatibility in accordance with applicable EMC standards. Unlike equipment conforming to VDE 0700, SECOTEC dryers conform to a strict industrial standard and are therefore equipped with a control cabinet to IP 54, a control transformer and fuses for the control and power circuits. The whole system is designed with maximum safety and reliability in mind.



User-friendly operation

Due to its convenient position on all models, the control panel can be viewed at a glance, whilst a dew point trend gauge integrated within the panel monitors dryer operation. System features include: Emergency/Off switch, LEDs to indicate "Thermal Mass Active" and "Refrigerant Compressor ON". All of these features provide outstanding ease of operation and further increase system reliability.



Outstanding reliability and durability

High quality, generously-sized components (e.g. in the condenser) ensure optimum flow at all times, even at high operating temperatures, and guarantee a long and dependable service life, e.g. stainless steel condensate separator*). Details such as the use of smooth-bore piping in the refrigeration circuit also contribute to exceptional system efficiency.



*) TA 5 model uses a zinc die-cast condensate separator

Equipment

General design

Tower construction with removable side panels, sheet steel panelling powder coated outside and galvanised inside; all cold components are insulated; all materials used are CFC-free; the built-in control cabinet is enclosure-protected to IP 54, air to air heat exchanger (model TA 8 upwards); condensate separating system, automatic condensate drain; scope of delivery includes refrigerant and oil.

Control panel

Equipped with dew point trend gauge, Emergency/ Off switch, LEDs to indicate "Thermal Mass Active" and "Refrigerant Compressor ON". LEDs for "High Dew Point" and "ECO DRAIN Alarm" are fitted as standard on TE models and upwards. TF models and upwards are equipped with dual operating hours counters.



Refrigerant circuit

Hermetically-sealed refrigerant circuit features large heat exchanger surface area and service valves, SECOTEC cycling control with thermal mass and automatic dew point control.



Accessories (optional)

Bypass piping system: This option ensures compressed air is supplied even while service work is carried out on the refrigeration dryer.

Technical specifications

Model *)	Flow rate in m³/min at 7 bar operating pressure **)	Differential pressure bar **)	Effective power consumption in kW **)			Power connection	Air connection (Female thread)	Condensate outlet mm	Dimensions H x W x D mm	Weight kg
			At 100 % rated flow capacity	At 50 % rated flow capacity	At 10 % rated flow capacity					
TA 5	0.60	0.07	0.25	0.14	0.04	230 V 50 Hz 1 Ph	G ¾	G ¼	630 x 484 x 779	70
TA 8	0.85	0.14	0.25	0.14	0.04					80
TA 11	1.25	0.17	0.28	0.15	0.04					85
TB 19	2.10	0.19	0.43	0.24	0.06	230 V 50 Hz 1 Ph	G 1	DN 10	620 x 540 x 963	108
TB 26	2.55	0.20	0.61	0.34	0.09					116
TC 31	3.20	0.15	0.73	0.40	0.11					155
TC 36	3.90	0.16	0.80	0.44	0.12	400 V 50 Hz 3 Ph	G 1¼	DN 10	774 x 660 x 1009	170
TC 44	4.70	0.15	0.90	0.50	0.14					200
TD 51	5.65	0.11	0.86	0.47	0.13					251
TD 61	7.00	0.15	1.10	0.61	0.17	400 V 50 Hz 3 Ph	G 1½	DN 10	759 x 1125 x 1187	251
TD 76	8.25	0.17	1.40	0.77	0.21					287
TE 91	10.15	0.15	1.15	0.63	0.17					570
TE 121	12.70	0.18	1.45	0.80	0.22	400 V 50 Hz 3 Ph	G 2	2x DN 10	1060 x 1520 x 1513	660
TE 141	14.30	0.24	1.60	0.88	0.24					660
TF 173	17.00	0.17	2.10	1.16	0.32					660
TF 203	21.00	0.16	2.20	1.21	0.33	400 V 50 Hz 3 Ph	DN 65	2x G ¼	1060 x 1757 x 1900	850
TF 251	25.00	0.19	2.50	1.38	0.38					850

*) Using refrigerant R 134 a; max. operating pressure 16 bar(g); max. compressed air inlet/ambient temperature 55/43°C
 **) Performance data for reference conditions to ISO 7183, Option A: Operating pressure 7 bar(g), ambient temperature + 25°C, air inlet temperature + 35°C, pressure dew point + 3°C. The flow rate and differential pressure change for other operating conditions.

Correction factors for deviating operating conditions (flow rates in m³/min x c...)

Deviating working pressure p at dryer inlet																Compressed air inlet temperature T _i						Ambient temperature T _a								
Modell	p bar(ü)	3	4	5	6	7	8	9	10	11	12	13	14	15	16	Modell	T _e (°C)	30	35	40	45	50	55	Modell	T _u (°C)	25	30	35	40	43
TA-TF	k _p	0.75	0.84	0.90	0.95	1.00	1.04	1.07	1.10	1.12	1.15	1.17	1.19	1.21	1.23	TA-TF	k _{Te}	1.20	1.00	0.83	0.72	0.60	0.49	TA-TF	k _{Ta}	1.00	0.99	0.97	0.94	0.92

Calculation of dryer flow rate under deviating conditions:
 Example:
 Operating pressure: Air inlet 10 bar (g) > Table > c_p = 1.10
 temperature: 40°C > Table > c_{ti} = 0.83
 Ambient temperature: 30°C > Table > c_{ta} = 0.99

Selected refrigeration dryer: TB 19 with 2.1 m³/min (V_{Reference})
 Max. possible flow rate under operating conditions
 $V_{max, operational} = V_{Reference} \times c_p \times c_{ti} \times c_{ta}$
 2.1 min³/min x 1.1 x 0.83 x 0.99 = 1.90 m³/min



Comprehensive design know-how



Typically operating at load capacities of 95 % or more, KAESER compressed air systems provide exceptional efficiency and produce application-specific quality

compressed air at lowest possible cost. Use this expertise to your advantage and let KAESER design your compressed air system.

Variant 1

For generally consistent air demand, the SECOTEC refrigeration dryer is located downstream from the air receiver.



Variant 2

For heavily fluctuating air demand, the SECOTEC dryer is located between the compressor, centrifugal separator with condensate drain and air receiver.



Dimensions

TA Series

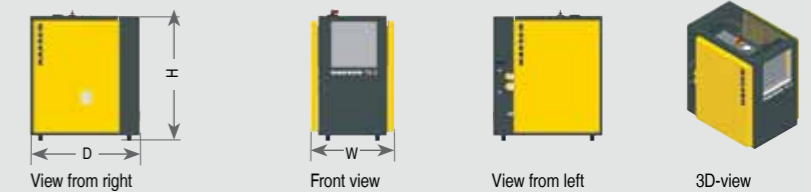

TB, TC, TD Series

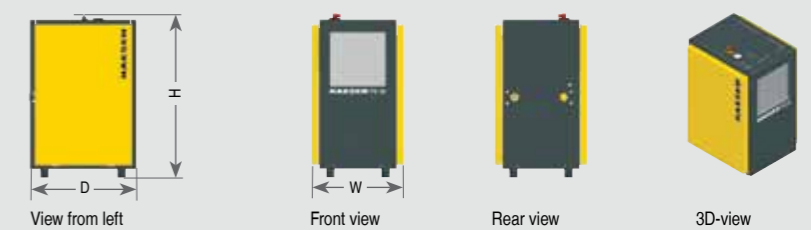

TE Series

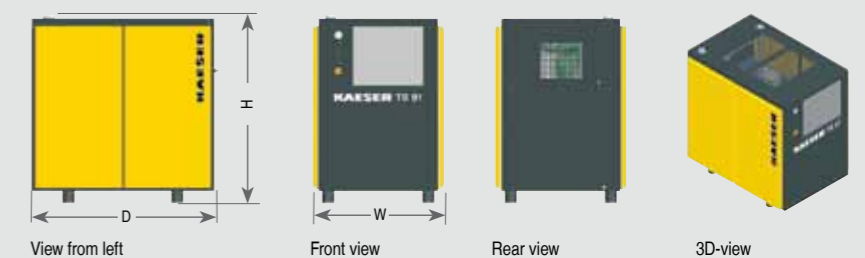

TF Series

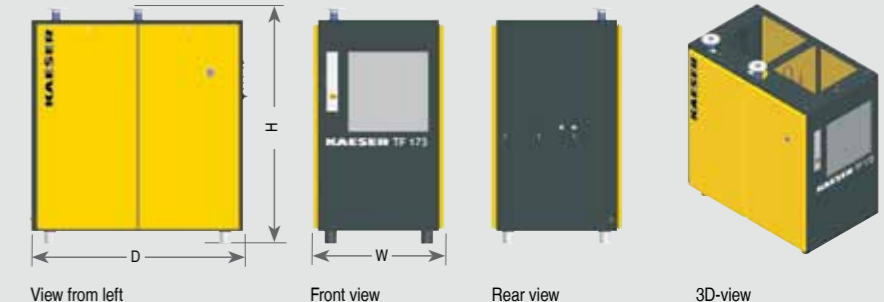

Installation of refrigeration dryers

Compressed air refrigeration dryers must be selected to suit actual operational conditions:

- The maximum possible flow rate through the refrigeration dryer rises with increasing working pressure.
- In contrast, the maximum possible flow rate through the dryer falls with increasing air inlet temperature.
- The maximum possible flow rate through the dryer also falls with increasing ambient temperature.

Choose the required grade of treatment according to your field of application:

Air treatment using a refrigeration dryer (pressure dew point +3 °C)

Application examples: Selection of treatment classes to ISO 8573-1 (2010)

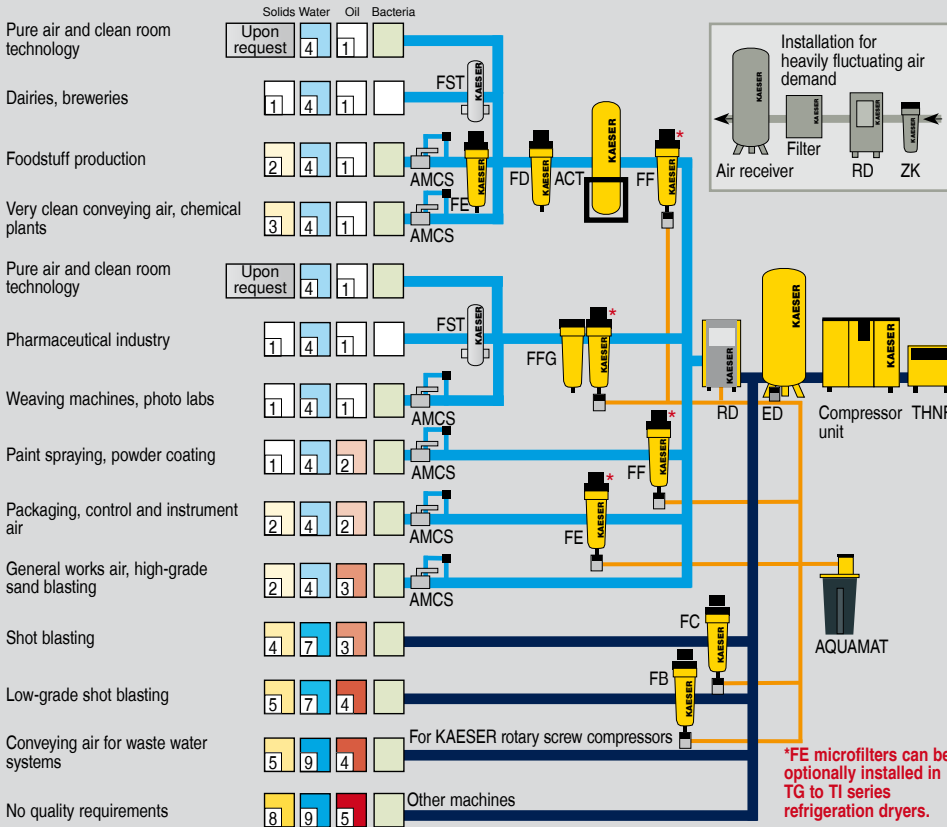

For non frost protected air systems: Compressed air treatment with a desiccant dryer (down to -70 °C pressure dew point)

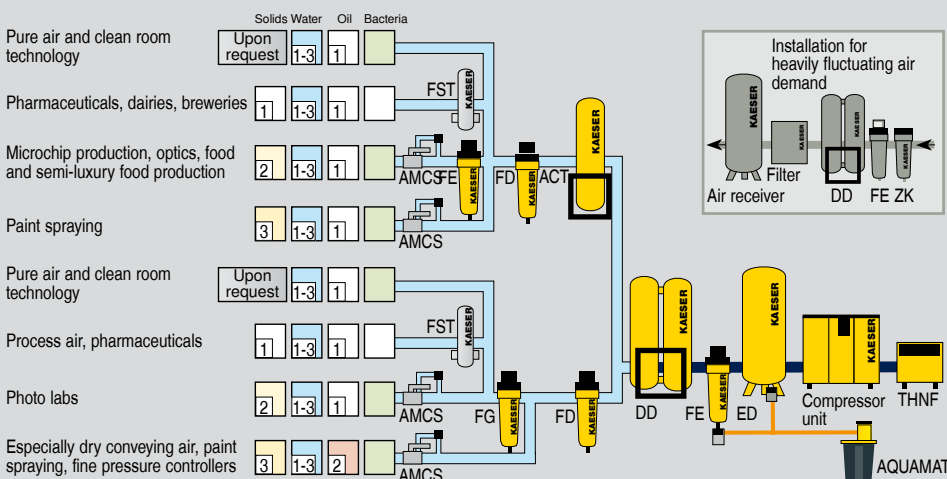

Explanation	
THNF	Bag filter
ZK	Centrifugal separator
ED	ECO DRAIN
FB / FC	Pre-filter
FD	Particulate filter
FE / FF	Microfilter
FG	Activated carbon filter
FFG	Activated carbon and microfilter combination
RD	Refrigeration dryer
DD	Desiccant dryers
ACT	Activated carbon adsorber
FST	Sterile filter, upon request
Aquamat	Aquamat
AMCS	Air-main charging system

Compressed air quality classes to ISO 8573-1(2010):

Solid particles/dust			
Class	max. particle count per m ³ of a particle size with d [µm]*		
	0.1 ≤ d ≤ 0.5	0.5 ≤ d ≤ 1.0	1.0 ≤ d ≤ 5.0
0	e.g. Consult KAESER regarding pure air and cleanroom technology		
1	≤ 20.000	≤ 400	≤ 10
2	≤ 400.000	≤ 6.000	≤ 100
3	Not defined	≤ 90.000	≤ 1.000
4	Not defined	Not defined	≤ 10.000
5	Not defined	Not defined	≤ 100.000
Particle concentration C _p in mg/m ³ *			
6	0 < C _p ≤ 5		
7	5 < C _p ≤ 10		
X	C _p > 10		

Water	
Class	Pressure dew point, in °C
0	e.g. Consult KAESER regarding pure air and cleanroom technology
1	≤ -70 °C
2	≤ -40 °C
3	≤ -20 °C
4	≤ +3 °C
5	≤ +7 °C
6	≤ +10 °C
Concentration of liquid water C _w in g/m ³ *	
7	C _w ≤ 0.5
8	0.5 < C _w ≤ 5
9	5 < C _w ≤ 10
X	C _w > 10

Oil	
Class	Total oil concentration (fluid, aerosol + gaseous) [mg/m ³]*
0	e.g. Consult KAESER regarding pure air and cleanroom technology
1	≤ 0.01
2	≤ 0.1
3	≤ 1.0
4	≤ 5.0
X	> 5.0

*) At reference conditions 20 °C, 1 bar(a), 0% humidity